

DISHWASHER FEATURES AND SPECIFICATIONS

*Stamped metal body

great for magnets!

*Authentic chrome trim

*Commercial Grade Stainless Steel Interior

*Energy Star Qualified

Capacity	<input type="checkbox"/>	<input type="checkbox"/>	<input type="checkbox"/>	<input type="checkbox"/>	<input type="checkbox"/>	<input type="checkbox"/>	14 Place Settings
Number of Cycles	<input type="checkbox"/>	<input type="checkbox"/>	<input type="checkbox"/>	<input type="checkbox"/>	<input type="checkbox"/>	<input type="checkbox"/>	4
Cycles	<input type="checkbox"/>	<input type="checkbox"/>	<input type="checkbox"/>	<input type="checkbox"/>	<input type="checkbox"/>	<input type="checkbox"/>	Heavy Duty, Normal, Light/ China, Rinse Only
Cycle Options	<input type="checkbox"/>	<input type="checkbox"/>	<input type="checkbox"/>	<input type="checkbox"/>	<input type="checkbox"/>	<input type="checkbox"/>	6
Lower Rack	<input type="checkbox"/>	<input type="checkbox"/>	<input type="checkbox"/>	<input type="checkbox"/>	<input type="checkbox"/>	<input type="checkbox"/>	2 Fold Down Rack Tines: 3 Position Back/2 Position Front Row
Upper Rack	<input type="checkbox"/>	<input type="checkbox"/>	<input type="checkbox"/>	<input type="checkbox"/>	<input type="checkbox"/>	<input type="checkbox"/>	2-Pos Adjus w/2-Pos Fold-Down Tines & 6 Sure-Hold® Clips
Sound Reduction System	<input type="checkbox"/>	<input type="checkbox"/>	<input type="checkbox"/>	<input type="checkbox"/>	<input type="checkbox"/>	<input type="checkbox"/>	Whisper Quiet® Plus (52 dBA)
Energy Guide (kWh/year)	<input type="checkbox"/>	<input type="checkbox"/>	<input type="checkbox"/>	<input type="checkbox"/>	<input type="checkbox"/>	<input type="checkbox"/>	334 (Energy Star Qualified)
Warranty	<input type="checkbox"/>	<input type="checkbox"/>	<input type="checkbox"/>	<input type="checkbox"/>	<input type="checkbox"/>	<input type="checkbox"/>	One Year Parts and Labor <input type="checkbox"/> <input type="checkbox"/> <input type="checkbox"/>
Electrical	<input type="checkbox"/>	<input type="checkbox"/>	<input type="checkbox"/>	<input type="checkbox"/>	<input type="checkbox"/>	<input type="checkbox"/>	15 OR 20 Ampere, 120 Volts, 60 Hertz (1/second). AC-ONLY. USE
	<input type="checkbox"/>	<input type="checkbox"/>	<input type="checkbox"/>	<input type="checkbox"/>	<input type="checkbox"/>	<input type="checkbox"/>	COPPER WIRE ONLY. GROUNDED CIRCUIT IS REQUIRED. A TIME-DELAY
	<input type="checkbox"/>	<input type="checkbox"/>	<input type="checkbox"/>	<input type="checkbox"/>	<input type="checkbox"/>	<input type="checkbox"/>	FUSE OR CIRCUIT BREAKER AND SEPARATE CIRCUIT IS RECOMMENDED.

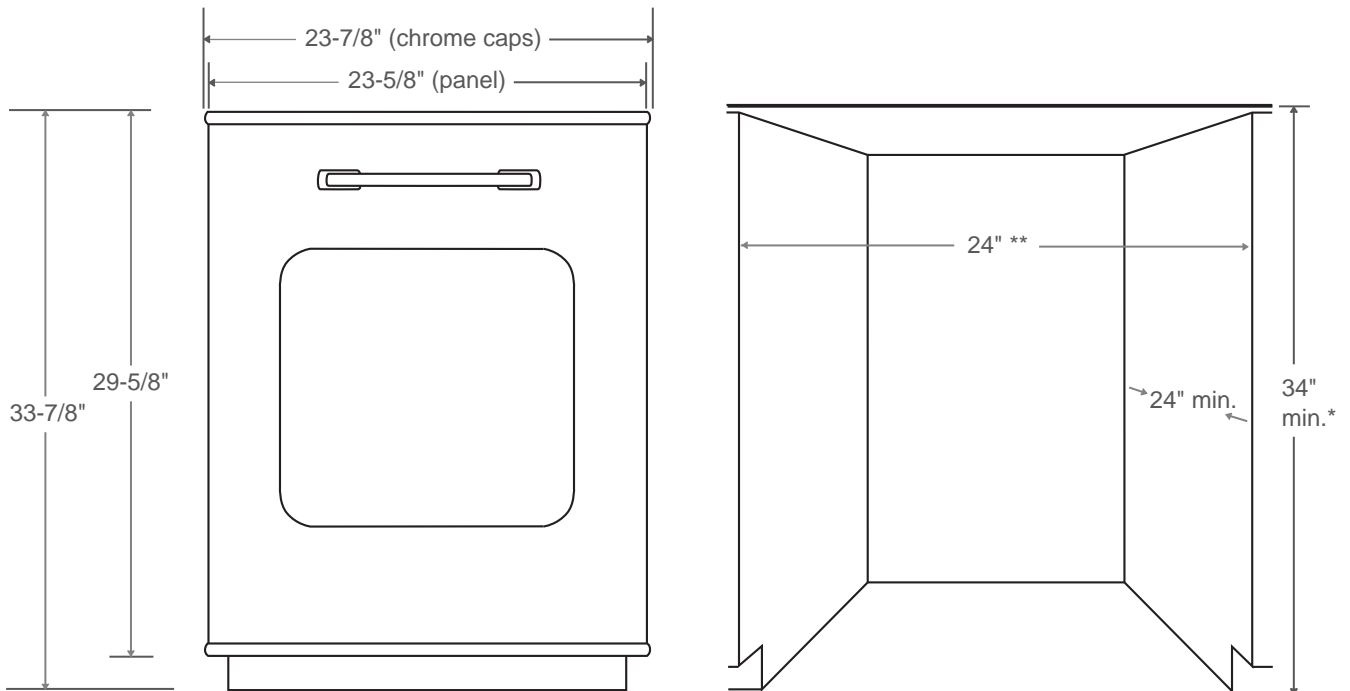

* Measured from the lowest point on the underside of countertop. May be reduced to 33-7/8" by removing wheels from dishwasher.

** Minimum, measured from narrowest point of opening.